

HEISLER

HL-70PS PAIL LABELER



The **HEISLER HL-70PS Labeler** is designed to replace the manual operation of applying pressure sensitive labels to round containers. The standard machine applies one label, automatically orienting the container for proper label to handle registration. The label is applied to the container from the center out for precise positioning.

Heisler can offer a host of solutions for pail handling needs including fully automated high speed denesting, lid placing, and pail palletizing.

Machine Options

- Right or Left Hand Model
- Thermal transfer printing option available
- “Baby-in-the-bucket” label sensor, placing the label on the same side of the container every time (U.S.A. only)
- Spare and wear parts package
- Steel-it-Paint
- Corrosion resistance package
- Casters for mobility
- Added conveyor lengths and accessories
- Bar code scanner for proper label detection
- Explosion-Proof package
- Fan fold label feed



Machine Operation

The fully automated HEISLER HL-70PS pail labeler uses a highly reliable pressure sensitive label applicator. The label is dispensed from the applicator onto the patented label gates once a pail has entered the pail orientation station. Once oriented for the proper positioning of the bail and/or other previously applied labels, the pail is released from the orientation station. The pail then passes through the label gates, where the label is applied and wiped down to ensure proper adhesion. The next pail enters the orientation station once the proceeding pail has cleared the label gates, starting the cycle over again.

Machine Features

- High speed operation, up to 30 CPM
- Uses pressure-sensitive labels on rolls
- Labels are applied to the pail from the center out for precise labeling
- Pails are automatically oriented for bail to label registration.
- Easy to maintain, uncomplicated design throughout allows for ease of use, basic service and adjustments
- Synchronized infeed stops
- PLC controlled
- Free life time technical phone support
- Patented Technology

www.heislerind.com

HEISLER
QUALITY, DURABILITY, SERVICE



Denesters • Case/Tray Packers • Lid Placers • Palletizers
Labelers • Bail-O-Matics • Turn Tables • System Integration

“We are dedicated to the success of your project”

...choice labeling solutions™

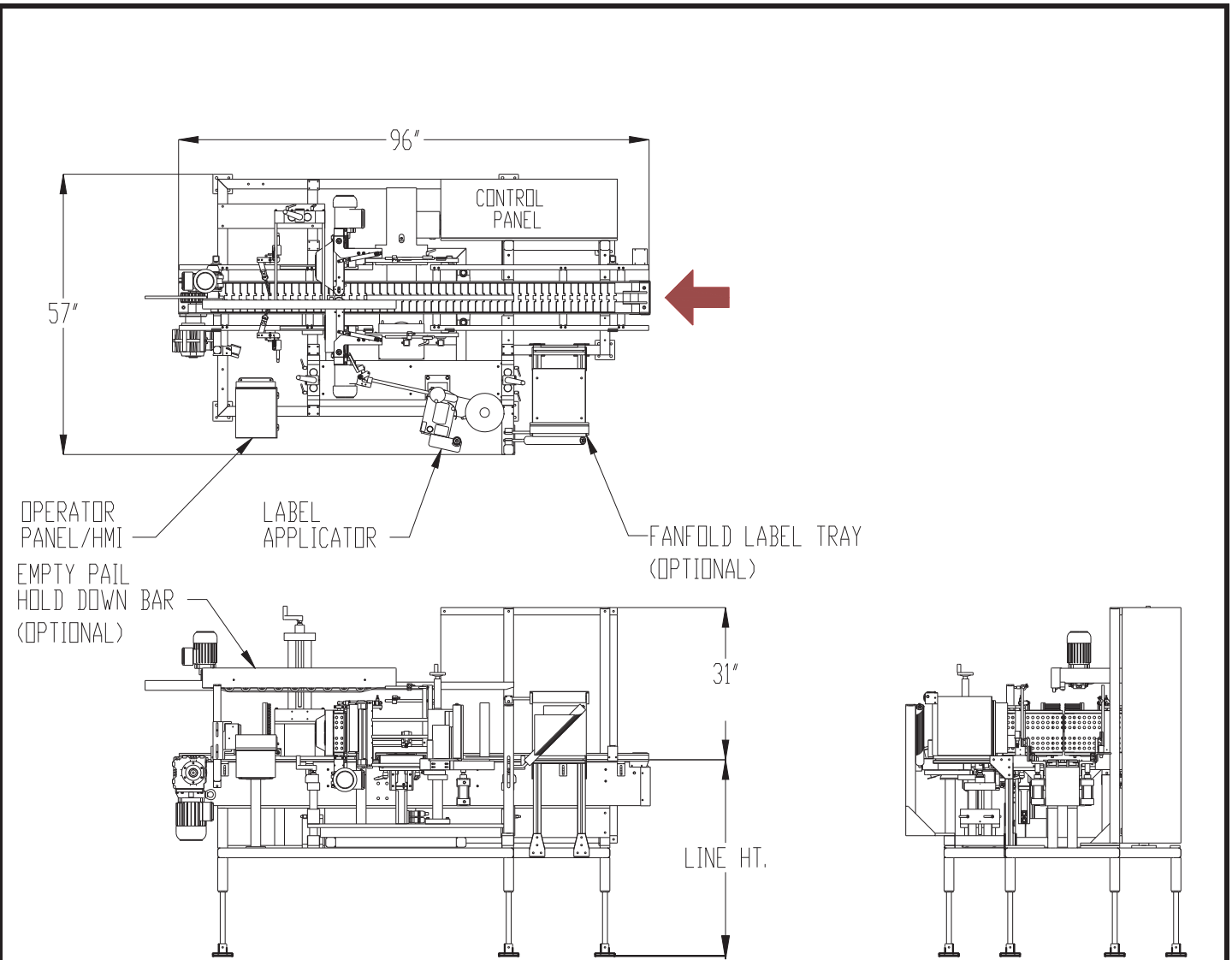

Technical Specification	HL-70PS
Container	Straight and or Conical Steel, Plastic, or Fiber
Label height and length	Min height 1", Min length 6", Max height 8.5", max length 34.5"
Compressed air connection	90 psi @ 5cfm
Electrical service	220/440 VAC, 3 Phase, 60 Hertz
Speed	Up to 30 Pails/Min.
Weight, net approximately	2,000 lbs.

HEISLER
QUALITY, DURABILITY, SERVICE

224 Passaic Ave, Fairfield, NJ
TEL 973-227-6300 • FAX 973-227-7627
www.heislerind.com